



Engineering Solutions For All Your Hang-Ups



GARMENT CONVEYOR CATALOGUE GC-09

www.srsconveyors.com sales@srsconveyors.com



CATALOGUE MG-93





CATALOGUE OC-250

WHY CHOOSE SRS CONVEYORS

Since 1962, SRS Conveyors have specialized in being a turn key garment material handling solutions provider. We assist our clients with everything from the initial design and layout to project management, programming, system integration/implementation, training, service and maintenance. Whether our client needs a simple storage system or a sophisticated automated sortation conveyor, SRS Conveyors has the equipment, staff and solutions to get the job done.



CATALOGUE TC-200

TABLE OF CONTENTS:

	PAGES
Introduction	1-2
Standard Garment Conveyor Model-ST.....	3
Standard Design and Construction	4
Slide Garment Conveyor Model-SC	5
Assembly Garment Conveyor Model-AC	6
Double Tier Garment Conveyor Model-DT	7
Single / Double Tier Garment Conveyor Model-SD..	8
Floor to Ceiling Double Tier Garment Conveyor Model FC-DT	9
Floor to Ceiling Garment Conveyor Model-FC.....	9
V-Dip Garment Conveyor Model-VD.....	10
Hat or Package Garment Conveyor Model-HC ..	11-12
Conveyor Control Options	13
Accessories	14

STANDARD GARMENT CONVEYOR MODEL-ST



INCREASE YOUR HANGING CAPACITY

Replacing your conventional garment racks with Well Products Model-ST, electric garment conveyor, you can increase your hanging capacity up to 40% by removing wastage of valuable aisle space, which in turn will provide your customers with a more prompt and efficient service. Convenient slots are provided for the identification of garments under your numbering system. Available in various shapes and sizes it is very simple to install and operate.

AVAILABLE SHAPES

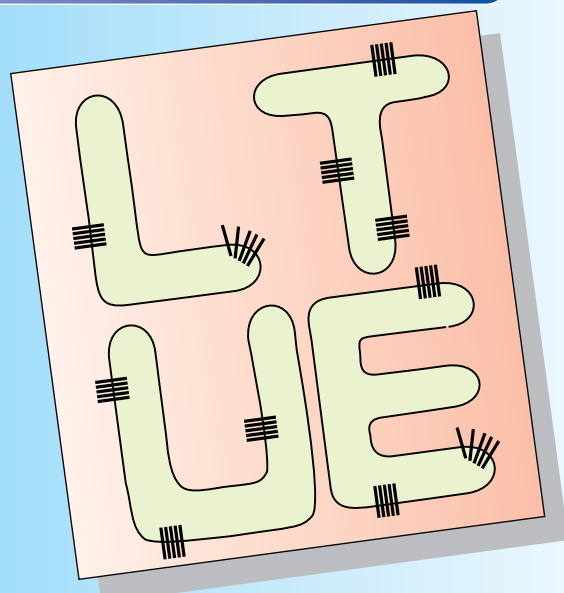

STANDARD DESIGN AND CONSTRUCTION

Track & Frame:

- Modular sections for easy installation and/or extensions
- Custom configuration for your unique specifications (multiple shapes, lengths, multi-levels and elevations)
- Floor and/or ceiling mounted
- Cross support 4" fabricated channel
- Frame construction 1-1/2" angle combined with 1-1/4" o.d. zinc plated tubing.
- Standard finish white or black (custom colours available upon request).

Conveyor Chain:

- 12" single or double tier steel link with chrome finish, offers 4, 5 or 10 garment slots per link
- Single or dual steel trolleys consists of chrome finish complete with side guide rollers
- Case hardened hinge pins and spacers for minimum wear
- Trolley bearings consist of 1-3/8" o.d. complete with nylon tires on steel cores

Electrical:

- All SRS garment conveyors are CSA approved
- Motor 1/2 h.p. to 1 h.p. totally enclosed fan cooled
- Input 115 volts / 60 hertz/ 1750 RPM (custom inputs available)
- Inverter drive with the following features
- Soft start / stop
- Variable speed
- Overload / jam protection
- Low energy consumption

Conveyor Drive Unit:

- 3/8" to 1/2" thick laser cut steel complete with 1-1/4" dia. Shaft
- Optional dual drive
- Permanently lubricated reducer
- 180° drive unit

Garment Conveyor Operating Controls:

- Hand Controller – Bi-directional three position switch
- Foot Controller – Bi-directional three position switch
- System 100 Controller:
- Shortest path taken
- Stacks multiple requests
- Prioritize the queue
- Forward / reverse manual control
- Secondary hand or foot control integration
- Remote terminal control
- Accommodates multiple tier conveyors
- Network multiple garment conveyors via daisy chain
- Fully integrated with POS of garment tracking software systems
- Optional customer information displayed
- Ability to integrate with other conveyor manufacturers

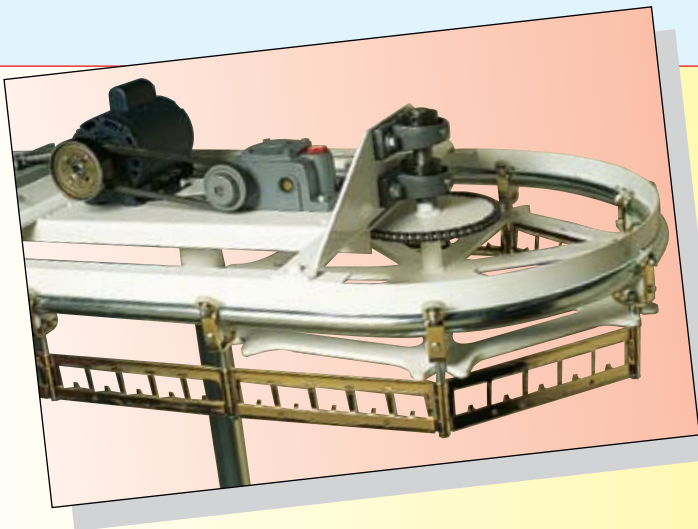

MODEL-ST SPECIFICATIONS

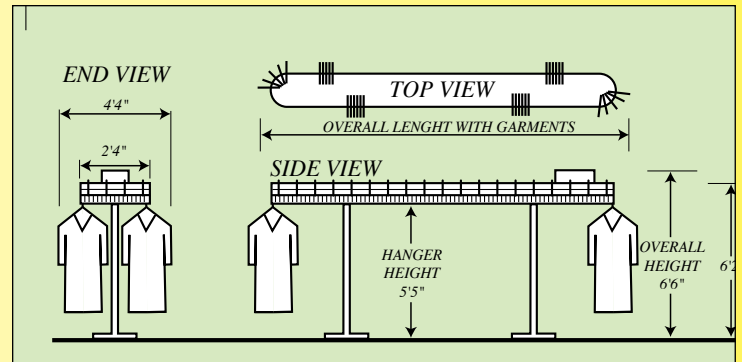

MODEL-ST SPECIFICATIONS

NUMBER OF SLOTS	LENGTH OF HANGING CAPACITY	TOTAL LENGTH WITHOUT GARMENTS
160	16' - 0"	6' - 10"
200	20' - 0"	8' - 10"
240	24' - 0"	10' - 10"
280	28' - 0"	12' - 10"
320	32' - 0"	14' - 10"
360	36' - 0"	16' - 10"
400	40' - 0"	18' - 10"
440	44' - 0"	20' - 10"
480	48' - 0"	22' - 10"
520	52' - 0"	24' - 10"
560	56' - 0"	26' - 10"
600	60' - 0"	28' - 10"
640	64' - 0"	30' - 10"
680	68' - 0"	32' - 10"
720	72' - 0"	34' - 10"
760	76' - 0"	36' - 10"
800	80' - 0"	38' - 10"
840	84' - 0"	40' - 10"
880	88' - 0"	42' - 10"
920	92' - 0"	44' - 10"
960	96' - 0"	46' - 10"
1000	100' - 0"	48' - 10"
1040	104' - 0"	50' - 10"

SLIDE GARMENT CONVEYOR MODEL-SC



KEEP YOUR ORDERS IN ORDER
 The Slide garment conveyor Model-SC is designed with no slots so that you are able to push together garments without having to lift and shift orders to fill empty gaps on your conveyor system. New garments are added behind old, maintaining perfect order by invoice number or by alphabetical order.

MODEL-SC SPECIFICATIONS

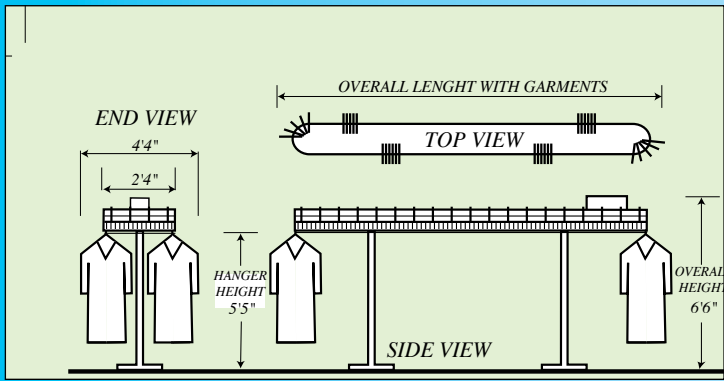

MODEL-SC SPECIFICATIONS

MODEL - SC HANGING CAPACITY	TOTAL LENGTH WITHOUT GARMENTS
16' - 0"	6' - 10"
20' - 0"	8' - 10"
24' - 0"	10' - 10"
28' - 0"	12' - 10"
32' - 0"	14' - 10"
36' - 0"	16' - 10"
40' - 0"	18' - 10"
44' - 0"	20' - 10"
48' - 0"	22' - 10"
52' - 0"	24' - 10"
56' - 0"	26' - 10"
60' - 0"	28' - 10"
64' - 0"	30' - 10"
68' - 0"	32' - 10"
72' - 0"	34' - 10"
76' - 0"	36' - 10"
80' - 0"	38' - 10"
84' - 0"	40' - 10"
88' - 0"	42' - 10"
92' - 0"	44' - 10"
96' - 0"	46' - 10"
100' - 0"	48' - 10"
104' - 0"	50' - 10"

ASSEMBLY GARMENT CONVEYOR MODEL-AC



ROTATE YOUR ASSEMBLY LINE

Fast automatic assembly operation is what the Well Products Assembly garment conveyor Model-AC provides. By bringing the desired assembly position to the operator automatically, walking is eliminated which is typical of most assembly operations. The Model-AC garment conveyor also cuts floor and assembly or checking time in half. Five invoice clips are provided per each one foot link for easy reading and assembly.

MODEL-AC SPECIFICATIONS

MODEL - AC NUMBERS OF ORDERS	LENGTH OF HANGING CAPACITY	TOTAL LENGTH WITHOUT GARMENTS
80	16' - 0"	6' - 10"
100	20' - 0"	8' - 10"
120	24' - 0"	10' - 10"
140	28' - 0"	12' - 10"
160	32' - 0"	14' - 10"
180	36' - 0"	16' - 10"
200	40' - 0"	18' - 10"
220	44' - 0"	20' - 10"
240	48' - 0"	22' - 10"
260	52' - 0"	24' - 10"
280	56' - 0"	26' - 10"
300	60' - 0"	28' - 10"
320	64' - 0"	30' - 10"
340	68' - 0"	32' - 10"
360	72' - 0"	34' - 10"
380	76' - 0"	36' - 10"
400	80' - 0"	38' - 10"
420	84' - 0"	40' - 10"
440	88' - 0"	42' - 10"
460	92' - 0"	44' - 10"
480	96' - 0"	46' - 10"
500	100' - 0"	48' - 10"
520	104' - 0"	50' - 10"

MODEL-AC SPECIFICATIONS

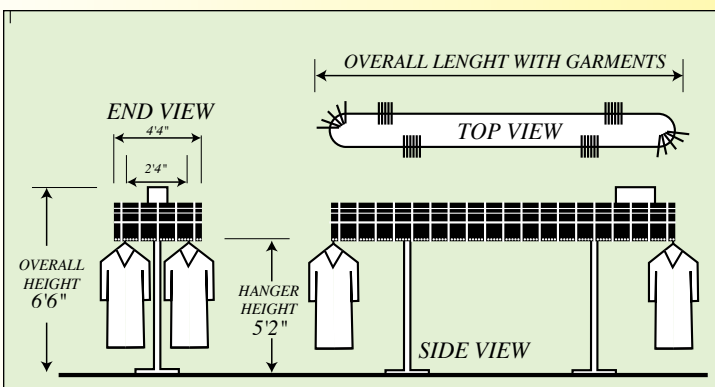

DOUBLE TIER GARMENT CONVEYOR MODEL-DT



GARMENT SPECIFICATIONS

GARMENT TYPE	BAG SIZE
SLACKS, SKIRTS, SHIRTS	30"
JACKETS & SUITS	38"
COATS & DRESSES	54"

DOUBLE YOUR STORAGE

Double your storage with Well Products Double Tier garment conveyor Model-DT. This operates with two levels of hanged garments, with the upper and lower tier rotating simultaneously with the same control. You are able to hang 4 times more garments than hanging space of conventional pipe rail of the same length, and garments are easily retrieved by the operator.

MODEL-DT SPECIFICATIONS

MODEL - DT SPECIFICATIONS

MODEL - DT NUMBER OF SLOTS	LENGTH OF HANGING CAPACITY	TOTAL LENGTH WITHOUT GARMENTS
320	32' - 0"	6' - 10"
400	40' - 0"	8' - 10"
480	48' - 0"	10' - 10"
560	56' - 0"	12' - 10"
640	64' - 0"	14' - 10"
720	72' - 0"	16' - 10"
800	80' - 0"	18' - 10"
880	88' - 0"	20' - 10"
960	96' - 0"	22' - 10"
1040	104' - 0"	24' - 10"
1120	112' - 0"	26' - 10"
1200	120' - 0"	28' - 10"
1280	128' - 0"	30' - 10"
1360	136' - 0"	32' - 10"
1440	144' - 0"	34' - 10"
1520	152' - 0"	36' - 10"
1600	160' - 0"	38' - 10"
1680	168' - 0"	40' - 10"

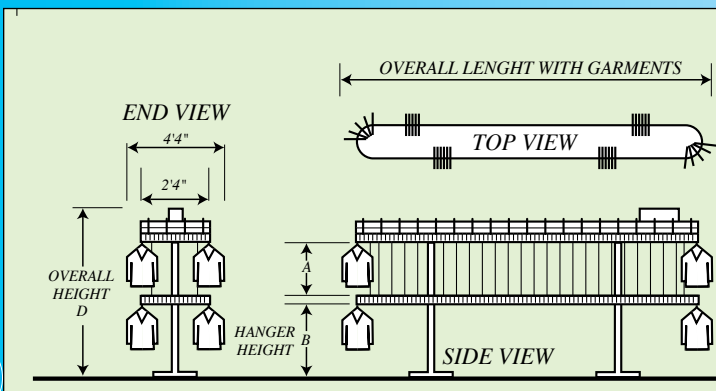

SINGLE/DOUBLE TIER GARMENT CONVEYOR MODEL-SD



TIER SPECIFICATIONS

MODEL-DT AND SD ARRANGE- MENT NO.	DIMENSION			OVERALL HEIGHT
	A UPPER TIER	B LOWER TIER	C SINGLE TIER	D OVERALL HEIGHT
1	34"	37"	63"	7'-4"
2	34"	45"	63"	8'-0"
3	34 "	60"	63"	9'-3"
4	42"	45"	63"	8'-8"
5	42"	60"	63"	9'-11"

MAXIMIZING A COMBINATION

The Single/Double Tier garment conveyor Model-SD allows you to have the best of both single and double tier storage. This conveyor provides a lower single tier for the accessibility of longer garments and provides maximum storage capacity in the double tier section. The length of the single tier and double tier are optional enabling you to meet all your hanging requirements.

MODEL-SD SPECIFICATIONS

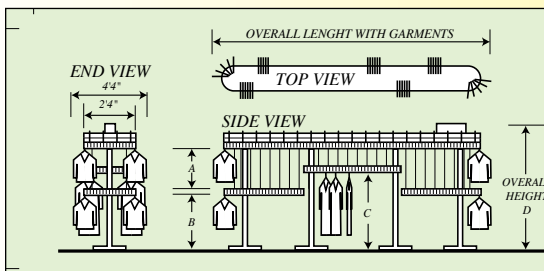

MODEL - SD SPECIFICATIONS

MODEL - SD NUMBER OF SLOTS	LENGTH OF HANGING CAPACITY	NUMBER OF SLOTS UPPER & LOWER TIER	NUMBER OF SLOTS SINGLE TIER	TOTAL LENGTH WITHOUT GARMENTS
240	24' - 0"	160	80	6' - 10"
300	30' - 0"	200	100	8' - 10"
360	36' - 0"	240	120	10' - 10"
420	42' - 0"	280	140	12' - 10"
480	48' - 0"	320	160	14' - 10"
540	54' - 0"	360	180	16' - 10"
600	60' - 0"	400	200	18' - 10"
660	66' - 0"	440	220	20' - 10"
720	72' - 0"	480	240	22' - 10"
780	78' - 0"	520	260	24' - 10"
840	84' - 0"	560	280	26' - 10"
900	90' - 0"	600	300	28' - 10"
960	96' - 0"	640	320	30' - 10"
1020	102' - 0"	680	340	32' - 10"
1080	108' - 0"	720	360	34' - 10"
1140	114' - 0"	760	380	36' - 10"
1200	120' - 0"	800	400	38' - 10"
1260	126' - 0"	840	420	40' - 10"

BASED ON 33.3% SINGLE TIER AND 66.6% DOUBLE TIER
PLEASE, SPECIFY THE NUMBER OF SLOTS FOR SINGLE AND DOUBLE TIER GARMENTS

FLOOR TO CEILING GARMENT CONVEYOR MODEL-FC



PUT YOUR CEILING TO WORK

Well Products Floor to Ceiling garment conveyor model-FC allows your ceiling to be put to work by loading garments on the floor level and by a press of a button taking it up and away to be stored until called by the operator. With your floor space now available, this permits you to store supplies or use the floor space as a production area. With a floor opening of 7' X 4'4" and the elevation change built to your specification, you are able to operate between floors or to a lower level.

MODEL-FC SPECIFICATIONS

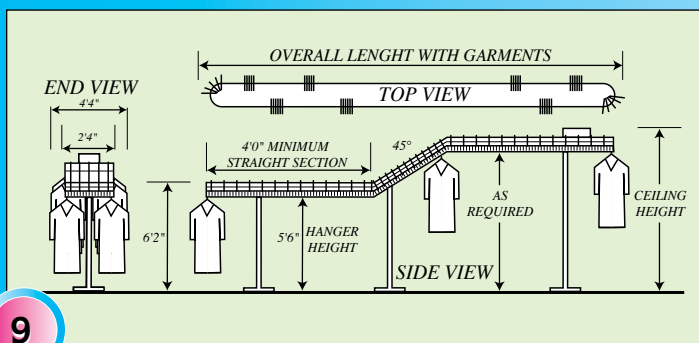

MODEL-FC SPECIFICATIONS

MODEL - FC NUMBER OF SLOTS	LENGTH OF HANGING CAPACITY	TOTAL LENGTH WITHOUT GARMENTS
380	38' - 0"	16' - 0"
420	42' - 0"	18' - 0"
460	46' - 0"	20' - 0"
500	50' - 0"	22' - 0"
540	54' - 0"	24' - 0"
580	58' - 0"	26' - 0"
620	62' - 0"	28' - 0"
660	66' - 0"	30' - 0"
700	70' - 0"	32' - 0"
740	74' - 0"	34' - 0"
780	78' - 0"	36' - 0"
820	82' - 0"	38' - 0"
860	86' - 0"	40' - 0"
900	90' - 0"	42' - 0"
940	94' - 0"	44' - 0"
980	98' - 0"	46' - 0"
1020	102' - 0"	48' - 0"
1060	106' - 0"	50' - 0"

V-DIP GARMENT CONVEYOR MODEL-VC



HEAD ROOM CHART

CEILING HEIGHT	HEAD ROOM UNDER 54" BAG
10' - 0"	4' - 3"
10' - 6"	4' - 9"
11' - 0"	5' - 3"
11' - 6"	5' - 9"
12' - 0"	6' - 3"
12' - 6"	6' - 9"
13' - 0"	7' - 3"
13' - 6"	7' - 9"
14' - 0"	8' - 3"

MAXIMIZE YOUR CEILING
 Well Products V-Dip garment conveyor Model-VC allows clothes to be stored overhead and in front of your store. This will impress your customers as well as enable you to put your ceiling to work. Conventional floor model conveyors require a minimum width of 4'4", but because the V-Dip can drop to your specification on one side of the conveyor to floor level, you only require 2 feet wide on the bottom of the V-Dip.

MODEL-VC SPECIFICATIONS

MODEL-VC SPECIFICATIONS

MODEL-VC NUMBER OF SLOTS	LENGTH OF HANGING CAPACITY	TOTAL LENGTH WITHOUT GARMENTS
500	50' - 0"	22' - 0"
540	54' - 0"	24' - 0"
580	58' - 0"	26' - 0"
620	62' - 0"	28' - 0"
660	66' - 0"	30' - 0"
700	70' - 0"	32' - 0"
740	74' - 0"	34' - 0"
780	78' - 0"	36' - 0"
820	82' - 0"	38' - 0"
860	86' - 0"	40' - 0"
900	90' - 0"	42' - 0"
940	94' - 0"	44' - 0"
980	98' - 0"	46' - 0"
1020	102' - 0"	48' - 0"
1060	106' - 0"	50' - 0"

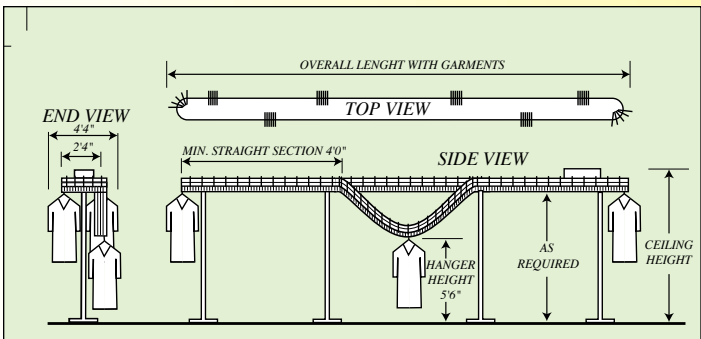

HAT OR PACKAGE GARMENT CONVEYOR MODEL-HC



SPACE SAVING DESIGN

Well Products Hat or Package garment conveyor model-HC and ST provides the most modern coat checking service available today. Used in restaurants, hotels, theaters, clubs resorts, hospitals, and dry cleaners, this equipment has been designed to eliminate unsightly coat racks and their aisle ways with richly automatic coat check conveyors. Because aisle space is now eliminated you are able to save up to 40% floor space and no longer have to run up and down aisles carrying coats and looking for numbers. You simply press a button and then the customer's hat or coat is brought around automatically.

For easy access to the customer's garment or hat, hangers hold a large numbered tag which is presented to the customer when checking in his or her coat. Once the customer returns to claim the coat he or she presents the numbered tag to the operator who locates the coat by simply pressing the number in the Well Products System 90 Digital Controller. The Digital Controller will automatically locate the desired slot where the customer's coat or hat is and bring it to the operator.

By combining hat or package with garments, the Model-HC allows for easy reaching for overhead bins and can store an arrangement of items such as shirts, laundry, sweaters, hats or any packed order. With the bins now rotating you are able to retrieve orders quickly and easily, and provide your customers with fast and efficient ser-

ACCESSORIES

MP-72



CN-11





MODEL-HC SPECIFICATIONS

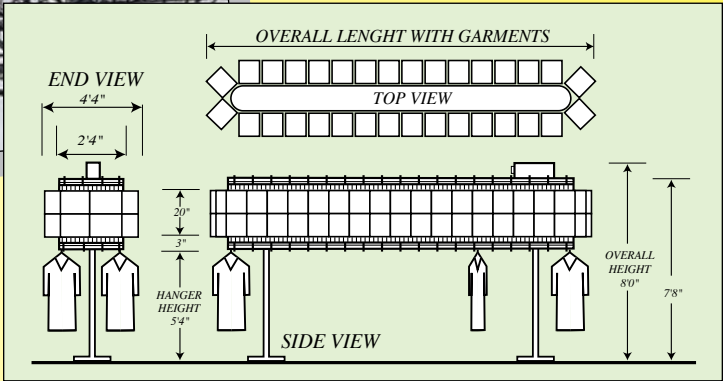

SH-15

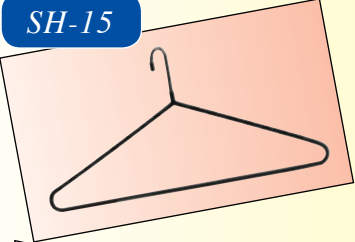

CH-18

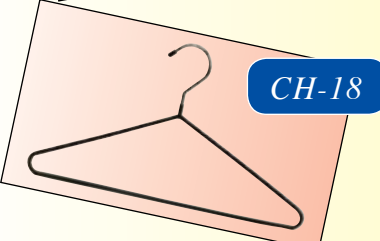

CH-21

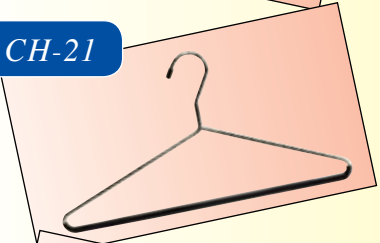

PH-24



MODEL-HC SPECIFICATIONS							
MODEL-HC	LENGTH OF	NUMBER	NUMBER OF HATS				LENGTH
NUMBER OF SLOTS	HANGING CAPACITY	OF BASKETS	ONE SHELF	TWO SHELF	THREE SHELF	FOUR SHELF	WITH BASKETS
160	16' - 0"	16	16	32	48	64	9' - 0"
200	20' - 0"	20	20	40	60	80	11' - 0"
240	24' - 0"	24	24	48	72	96	13' - 0"
280	28' - 0"	28	28	56	84	112	15' - 0"
320	32' - 0"	32	32	64	96	128	17' - 0"
360	36' - 0"	36	36	72	108	144	19' - 0"
400	40' - 0"	40	40	80	120	160	21' - 0"
440	44' - 0"	44	44	88	132	176	23' - 0"
480	48' - 0"	48	48	96	144	192	25' - 0"
520	52' - 0"	52	52	104	156	208	27' - 0"
560	56' - 0"	56	56	112	168	224	29' - 0"
600	60' - 0"	60	60	120	180	240	31' - 0"
640	64' - 0"	64	64	128	192	256	33' - 0"
680	68' - 0"	68	68	136	204	272	35' - 0"
720	72' - 0"	72	72	144	216	288	37' - 0"
760	76' - 0"	76	76	152	228	304	39' - 0"
800	80' - 0"	80	80	160	240	320	41' - 0"

FOOT CONTROL

This Bi-directional foot control allows you to lock out another person when more than one foot control is being used for one conveyor. The foot switch operates on 24 volts, which adds to the safety of the operation.



EX-72

HAND CONTROL

The Hand switch can be mounted from the conveyor frame or mounted remotely, and operates the conveyor in both directions on 24 volts.



SD-70



SYSTEM 100 DIGITAL CONVEYOR CONTROL

Significantly minimize your retrieval time and maximize your customer service with the state of the art System 100 Digital Conveyor Control. It has all the advanced features that you require and can also be fully integrated with innovative systems.

- Shortest path taken
- Stacks multiple requests
- Prioritize the queue
- Forward / reverse manual control
- Secondary hand or foot control integration
- Remote terminal control
- Accommodates multiple tier conveyors
- Network multiple conveyors via daisy chain
- Fully integrated with POS of garment tracking software systems
- Optional customer information displayed
- Ability to integrate with other conveyor manufacturers



DIVIDERS

Alphabetical or numeral dividers come in white or black and are offered in two different shapes.

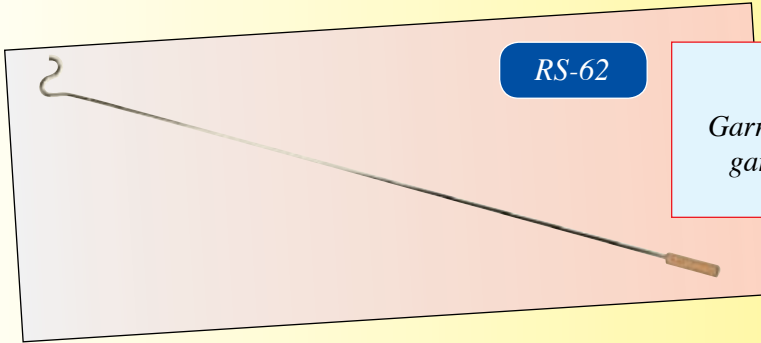
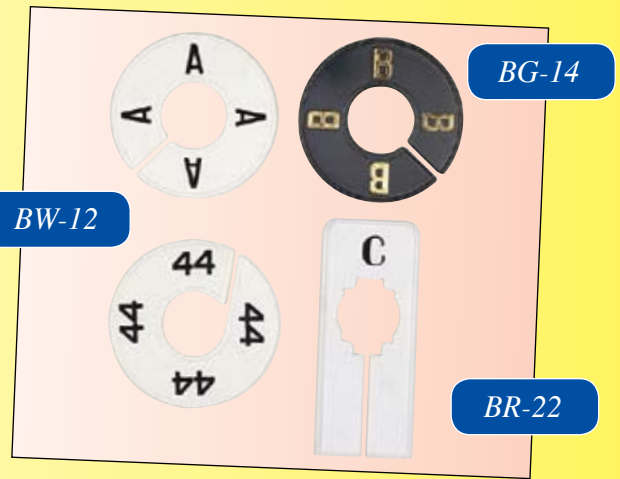

REACHING STICK

Garment reaching stick is used for reaching upper tier garments and is made from light weight aluminum.

COUNTER HOOK
Side mounted counter hook is offered in polished chrome or brass plating and is mounted on the side of the counter for sturdiness.

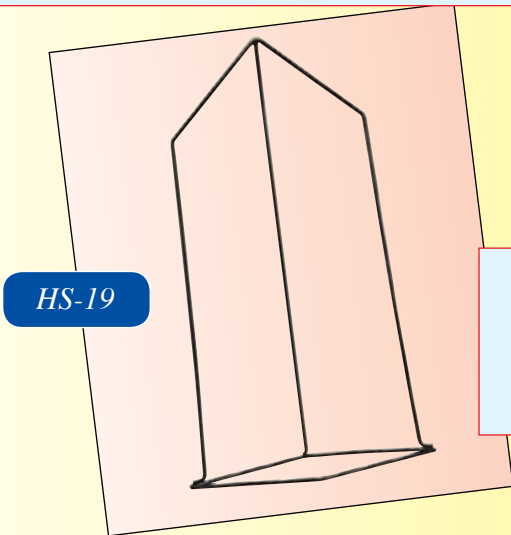
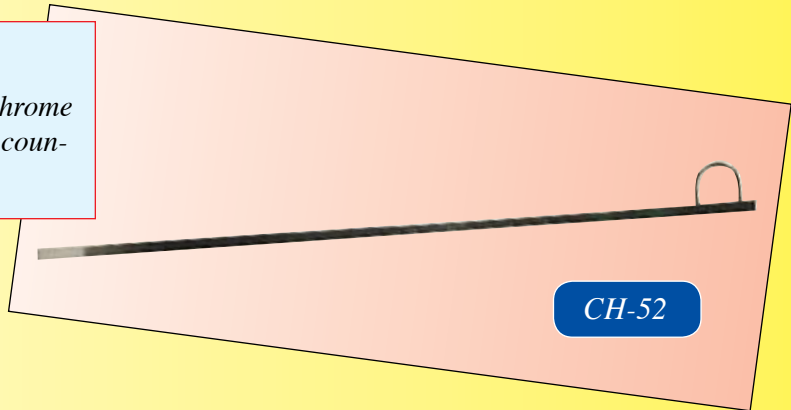

HANGER STACKER

Chrome plated wire hanger stacker is used for storing hangers orderly.

CONVEYOR NUMBERS
These self adhesive number stickers are applied to the conveyor link when using a numbering system.

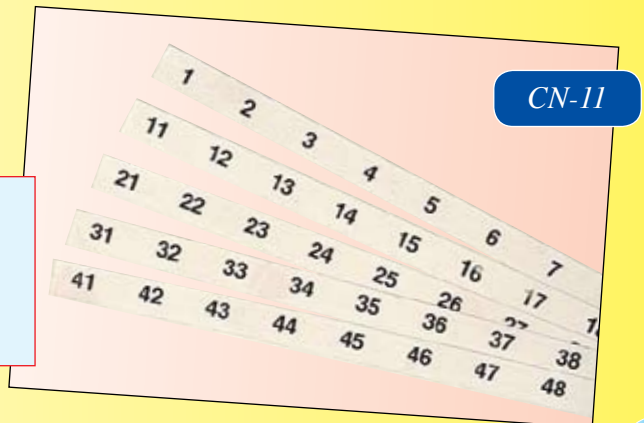



MANUFACTURED BY:

SRS Conveyors
105 Riviera Drive
Markham, Ontario
L3R 5J7 Canada
Phone: 1-800-267-9355 / 905-475-7717
Fax: 905-475-7709
website: www.srsconveyors.com

DISTRIBUTED BY:

